

This Page Is Inserted by IFW Operations
and is not a part of the Official Record

BEST AVAILABLE IMAGES

Defective images within this document are accurate representations of the original documents submitted by the applicant.

Defects in the images may include (but are not limited to):

- BLACK BORDERS
- TEXT CUT OFF AT TOP, BOTTOM OR SIDES
- FADED TEXT
- ILLEGIBLE TEXT
- SKEWED/SLANTED IMAGES
- COLORED PHOTOS
- BLACK OR VERY BLACK AND WHITE DARK PHOTOS
- GRAY SCALE DOCUMENTS

IMAGES ARE BEST AVAILABLE COPY.

**As rescanning documents *will not* correct images,
please do not report the images to the
Image Problem Mailbox.**



INTERNATIONAL APPLICATION PUBLISHED UNDER THE PATENT COOPERATION TREATY (PCT)

(51) International Patent Classification 6: E21B 43/10	A2	(11) International Publication Number: WO 97/17526
<p>(21) International Application Number: PCT/GB96/02745</p> <p>(22) International Filing Date: 8 November 1996 (08.11.96)</p> <p>(30) Priority Data: 9522926.6 9 November 1995 (09.11.95) GB</p> <p>(71) Applicant (for all designated States except US): PETRO-LINE WIRELINE SERVICES LIMITED (GB/GB); Off-shore Technology Park, Claymore Drive, Bridge of Don, Aberdeen AB23 8GD (GB).</p> <p>(72) Inventor; and (75) Inventor/Applicant (for US only): CAMPBELL, Alasdair (GB/GB); 38 Bruce Crescent, Ellon AB41 9BW (GB).</p> <p>(74) Agents: McCALLUM, William, Potter et al.; Cruickshank & Fairweather, 19 Royal Exchange Square, Glasgow G1 3AE (GB).</p>		<p>(43) International Publication Date: 15 May 1997 (15.05.97)</p> <p>(81) Designated States: AL, AM, AT, AU, AZ, BA, BB, BG, BR, BY, CA, CH, CN, CU, CZ, DE, DK, EE, ES, FI, GB, GE, HU, IL, IS, JP, KE, KG, KP, KR, KZ, LC, LK, LR, LS, LT, LU, LV, MD, MG, MK, MN, MW, MX, NO, NZ, PL, PT, RO, RU, SD, SE, SG, SI, SK, TJ, TM, TR, TT, UA, UG, US, UZ, VN, ARIPO patent (KE, LS, MW, SD, SZ, UG), Eurasian patent (AM, AZ, BY, KG, KZ, MD, RU, TJ, TM), European patent (AT, BE, CH, DE, DK, ES, FI, FR, GB, GR, IE, IT, LU, MC, NL, PT, SE), OAPI patent (BF, BJ, CF, CG, CI, CM, GA, GN, ML, MR, NE, SN, TD, TG).</p> <p>Published Without international search report and to be republished upon receipt of that report.</p>
(54) Title: DOWNHOLE ASSEMBLY FOR INSTALLING AN EXPANDABLE TUBING		
<p>(57) Abstract</p> <p>An assembly (10) for installing expandable tubing in a bore comprises: a length of tubing (14) including an expandable portion and an anchor (24) for releasably fixing the tubing in the bore; and a mandrel (12) for connection to a running string (19) and for carrying the tubing into the bore. The mandrel (12) includes an expander cone (18) for expanding the tubing, the cone (18) being initially located towards the lower end of the tubing, and a coupling (20) for releasably mounting the tubing on the mandrel. The tubing is releasable from the coupling (20) by manipulation of the mandrel following fixing of the tubing in the bore. The coupling is re-engagable with the tubing by further manipulation of the mandrel to permit manipulation of the tubing to release the anchor and permit withdrawal of the assembly from the bore. A coupling (44) may also be provided for releasing the expanding cone from the mandrel.</p>		

FOR THE PURPOSES OF INFORMATION ONLY

Codes used to identify States party to the PCT on the front pages of pamphlets publishing international applications under the PCT.

AM	Armenia	GB	United Kingdom	MW	Malawi
AT	Austria	GE	Georgia	MX	Mexico
AU	Australia	GN	Guinea	NE	Niger
BB	Barbados	GR	Greece	NL	Netherlands
BE	Belgium	HU	Hungary	NO	Norway
BF	Benin	IE	Ireland	NZ	New Zealand
BG	Bulgaria	IT	Italy	PL	Poland
BJ	Benin	JP	Japan	PT	Portugal
BR	Brazil	KE	Kenya	RO	Romania
BY	Belarus	KO	Kyrgyzstan	RU	Russian Federation
CA	Canada	KP	Democratic People's Republic of Korea	SD	Sudan
CF	Central African Republic	KR	Republic of Korea	SE	Sweden
CG	Congo	KZ	Kazakhstan	SG	Singapore
CH	Switzerland	LI	Liechtenstein	SI	Slovenia
CI	Cote d'Ivoire	LK	Sri Lanka	SK	Slovakia
CN	China	LR	Liberia	SN	Senegal
CY	Cyprus	LT	Lithuania	SE	Switzerland
CZ	Czech Republic	LU	Luxembourg	TD	Chad
DE	Germany	LV	Latvia	TG	Togo
DK	Denmark	MC	Monaco	TJ	Tajikistan
EE	Estonia	MD	Republic of Moldova	TT	Trinidad and Tobago
ES	Spain	MG	Madagascar	UA	Ukraine
FI	Finland	ML	Mali	UG	Uganda
FR	France	MN	Mongolia	US	United States of America
GA	Gabon	MR	Mauritania	UZ	Uzbekistan
				VN	Viet Nam

DOWNHOLE ASSEMBLY FOR INSTALLING AN EXPANDABLE TUBING

This invention relates to a downhole assembly, and in particular to an assembly for use in installing expandable tubing in a borehole.

WO-A-93\25800 (Shell Internationale Research), the
5 disclosure of which is incorporated herein by reference, discloses a method of completing an uncased section of a borehole in an underground formation. A liner provided with overlapping longitudinal slots is fixed at a predetermined position in the borehole. A tapered
10 expansion mandrel is then moved through the liner and expands the liner to a diameter larger than the mandrel maximum diameter. Ideally, the liner is expanded to such an extent that it contacts the bore wall.

The preferred method for installing the tubing is to
15 run the tubing into the bore on the end of a running string with the mandrel already positioned at the lower end of the tubing. The expansion mandrel is then pulled upwardly through the tubing.

It is among the objectives of the various aspects of
20 the present invention to provide assemblies which facilitate retrieval of at least the running string following an unsuccessful or aborted expandable tubing installation operation.

According to a first aspect of the invention there is
25 provided an assembly for installing expandable tubing in a bore, the assembly comprising: a length of tubing including

an expandable portion and means for releasably fixing the tubing in the bore; and a mandrel for connection to a running string and for carrying the tubing into the bore, the mandrel including means for expanding the expandable portion of tubing, said expanding means being initially located towards the lower end of said expandable portion, and means for releasably mounting the tubing on the mandrel, the tubing being releasable from the mounting means by manipulation of the mandrel following fixing of the tubing in the bore, and the mounting means being re-engageable with the tubing by further manipulation of the mandrel to permit manipulation of the tubing to release the fixing means and permit withdrawal of the assembly from the bore.

Thus, in use, if problems are encountered prior to or during expansion of the tubing, the mandrel of the present invention may be re-engaged with the tubing and the tubing then released from the bore such that the assembly may be retrieved from the bore.

To facilitate understanding of the invention the terms "upper" and "lower" have been used herein to indicate the relative positioning of various parts and to refer to parts of a borehole. However, such language is not to be construed as limiting the scope of the invention, which may be used in horizontal and inclined boreholes with equal utility.

Preferably, means is also provided for releasing the expanding means from the mandrel. Thus, if, for example,

the expanding operation encounters difficulties at a stage where the tubing has been expanded to such an extent that it cannot be retrieved from the bore, the larger diameter expanding means may be released such that the mandrel and running string may be removed from the bore. If necessary, the parts of the assembly remaining in the bore, that is the tubing and the expanding means, may then be milled out. Most preferably, the expanding means and the means for releasably mounting the tubing to the mandrel are linked and are releasable from the mandrel as one. This facilitates recovery of the running string if the mounting between the mandrel and the tubing is damaged or cannot be operated.

Preferably also, the means for releasing the expanding means from the mandrel is actuated by fluid pressure, conveniently by means of fluid which is pumped from the surface through the running string and a fluid passage defined by the mandrel. A restriction may be provided in the passage, or may be dropped or pumped down the string, to allow creation of a pressure drop and actuation of a piston to release keys or lugs locking the expanding means and the mandrel together. Preferably also, the means for releasably mounting the tubing to the mandrel includes an open-ended J-slot arrangement, such that re-engagement of the tubing with the mounting means may be achieved merely by manipulation of the running string. Alternatively, other arrangements as known to the those of skill in the art may be utilised, including latches, collets,

retractable\extendable keys and the like.

Preferably also, the means for releasably mounting the tubing on the mandrel includes a link for fixing the tubing on the mandrel while running in to the bore, to minimise the possibility of the tubing being inadvertently released from the mandrel by the shocks and bumps experienced during run in. Conveniently, the link is a shear link, such as a pin or ring, which may be released by jarring the running string.

Preferably also, the means for releasably fixing the tubing in the bore includes means for automatically latching the tube in the bore on downward axial movement of the tubing relative to the bore and means for releasing the tubing from the bore on one or both of subsequent axial movement of the tubing relative to the bore and rotational movement of the tubing relative to the bore. Conveniently, said automatic latching means and tubing releasing means are combined in a single fixing means such as a stab in/rotate out receptacle, which receptacle may include an open-ended J-slot, a ratchet thread, offset latching fingers and profiles, or any other suitable arrangement known to those of skill in the art.

Preferably also, the assembly includes a barrier to prevent debris falling into the upper end of the tubing, which debris might otherwise interfere with the movement of the expanding means through the tubing. Conveniently, the barrier is in the form of a junk catcher mounted on the lower end of the string or the upper end of the mandrel.

A sand screen or the like may be mounted on the tubing, to be pushed into contact with the bore wall on expansion of the tubing.

According to another aspect of the invention there is
5 provided an assembly for installing expandable tubing in a bore, the assembly comprising: a length of tubing including an expandable portion and means for releasably fixing the tubing in the bore; a mandrel for connection to a running string and for carrying the tubing into the bore, the
10 mandrel including means for expanding the expandable portion of tubing, said expanding means being initially located towards the lower end of said expandable portion; and means for releasably mounting said expanding means on the mandrel, whereby the expanding means is releasable from
15 the mandrel to permit withdrawal of the assembly from the tubing and the bore.

In the absence of an assembly in accordance with this aspect of the invention if, for whatever reason, it is only possible to pull the mandrel part way through the length of
20 tubing to be expanded, the mandrel and the string on which the mandrel is mounted will remain jammed in the bore. Even if possible, removal or retrieval of such a jammed string from a bore is a time consuming and expensive operation.

25 These and other aspects of the present invention will now be described, by way of example, with reference to the accompanying drawings, in which:

Figure 1 is a sectional view of an assembly for use in

installing expandable tubing in accordance with a preferred embodiment of the present invention, the assembly being shown in run-in-position;

5 Figure 2 is a sectional view of the lower end of the assembly of Figure 1 and a cooperating packer-mounted latch;

Figure 3 is a view of a J-slot for mounting the expandable tubing to the mandrel of the assembly of Figure 1;

10 Figure 4 is a sectional view of the assembly of Figure 1, and illustrating the assembly following release of the expandable tubing from the string and commencement of the expanding operation; and

15 Figure 5 is a sectional view of the assembly of Figure 1, following release of the expanding cone from the running string.

Reference is first made to Figure 1 of the drawings, which illustrates an assembly 10 for use in installing expandable tubing in a bore. The assembly 10 includes a 20 central mandrel 12 on which a tubing assembly 13 including a length of expandable slotted tubing (EST) 14 is mounted. In this example a sand screen 15 is provided over the exterior of the tubing 14. The mandrel 12 is connected to a running string 19 formed of drill pipe, and indeed 25 portions of the mandrel are formed from sections of drill pipe 16. The upper end of the mandrel 12 carries a junk catcher 17 to prevent debris falling into the tubing 14. The lower end of the mandrel 12 carries an expander cone 18

and is initially coupled to the tubing assembly 13 via means including a mandrel coupling portion 20. The corresponding tubing coupling portion 22 is fixed to the lower end of the expandable tubing 14. Extending below the tubing coupling portion 22 is an anchor 24 (Figure 2) for
5 engaging a packer-mounted latch assembly 26, in this example the anchor latch assembly being a Baker K22.

The assembly 10, carrying the tubing assembly 13, is run into a borehole including an uncased section in which
10 the packer-mounted latch assembly 26 has already been located. The anchor 24 includes externally threaded fingers 28 which are deflected inwardly as the anchor 24 is moved into the latch assembly 26, and which then spring out to engage the internally threaded end portion 30 of the
15 latch assembly 26. Thus to remove the anchor 24 from the latch assembly 26 it is necessary to rotate the anchor 24 relative to the assembly 26.

The coupling portions 20, 22 are initially connected by means of shear screws 32, and the mandrel coupling
20 portion 20 also defines a lug 34 which is initially located within the longer leg of an open ended J-slot 36 defined on the tubing coupling portion 22. The J-slot 36 is shown in greater detail in Figure 3 of the drawings. In normal operation, it is merely necessary to pull up on the string
25 to shear the screws 32 to release the mandrel 12 from the tubing assembly 13, once the assembly 13 has been fixed in the bore by the anchor latch assembly 24, 26. Pulling upwardly on the string lifts the lug 34 out of the J-slot

36 and brings the expanding cone 18 up through the tubing 14. In a normal operation, the expander cone 18 will be pulled all the way through the tubing 14, which will be expanded outwardly to push the sand screen 15 into contact with the bore wall. Once the expander cone 18 has cleared the uppermost section of tubing 14, the string 19, mandrel 12 and expander cone 18 may be removed from the bore. However, if a problem is encountered before the expansion operation is commenced, one aspect of the present invention allows the tubing assembly 13 to be re-engaged with the mandrel 12, to allow release of the anchor 24 from the latch assembly 26, as described below.

In the event of a problem, the mandrel 12 is lowered into the bore such that the lug 34 passes into the J-slot 36. The mandrel 12 is lowered until the lug 34 engages the lower J-slot stop 38. The mandrel 12 is then rotated relative to the fixed tubing assembly 13 such that on lifting the mandrel 12 the lug 34 is lifted into the blind leg 42 of the J-slot. The mandrel 12 is now rotated and the engagement of the lug 34 with the wall of the J-slot 36 causes the tubing assembly 13 and anchor 24 to rotate with the mandrel 12, such that the anchor 24 may be released from the fixed latch assembly 26. The assembly 10, and the tubing assembly 13, may then be retrieved from the bore.

In the event that some expansion of the tubing 14 has taken place (Figure 4) before the expansion operation is aborted, it may not be possible to remove the tubing assembly 13 from the bore, as the diameter of the expanded

tubing 14 may be larger than that of the bore liner or other restrictions above the assembly 13. In these circumstances, it is necessary that the tubing assembly 13 remains in the bore, however a second aspect of the invention permits the mandrel 12 and string 19 to be
5 retrieved, as explained below.

The expander cone 18 is mounted on the upper end of the mandrel coupling portion 20 and is held axially relative to the mandrel 12 by keys 44 which are normally
10 maintained in an extended position by a stepped profile tubular supporting collar 46 at the lower end of the mandrel 12. In addition, the tubing coupling portion 22 includes radially extending torque screws 48 normally
15 located in open ended slots 50 in the lower end of the mandrel 12; the screws 48 facilitate transfer of torque from the mandrel 12 to the tubing coupling portion 22 if the anchor 24 is to be released from the latch assembly 26.

The support collar 46 is normally fixed relative to the mandrel 12 by shear pins 52, and thus prevents inward
20 movement of the keys 44 and release of the expander cone 18 from the mandrel 12. However, by dropping a steel ball 54 (Figure 5) down the string to land on a seat 56 provided by a further inner collar 58, it is possible to pump down on
25 the ball 54 and create a pressure difference across the ball 54 sufficient to shear the pins 52 and move the support collar 46 downwardly. Downward movement of the stepped profile collar 46 allows the keys 44 to move inwardly, thus releasing the expander cone 18 from the

mandrel 12. The mandrel may then be removed from the assembly 10; as illustrated in Figure 5 of the drawings.

If deemed necessary or desirable, the parts of the assembly 10 remaining in the bore and the tubing assembly 5 13 may then be milled out.

From the above-description it will be apparent to those of skill in the art that this embodiment of the present invention provides for an assembly 10 which provides two different options for releasing the running 10 string in the event of a problem with the tubing running and expanding assembly 10 or the tubing assembly 13 itself. Of course in other embodiments these features may be provided separately, rather than both being provided in a single assembly 10.

15 It will also be clear to those of skill in the art that the above-described is merely exemplary of the present invention, and that various modifications and improvements may be made thereto without departing from the scope of the invention.

CLAIMS:

1. An assembly for installing expandable tubing in a bore, the assembly comprising:

a length of tubing including an expandable portion and
5 means for releasably fixing the tubing in the bore; and

a mandrel for connection to a running string and for
carrying the tubing into the bore, the mandrel including
means for expanding the expandable portion of tubing, said
expanding means being initially located towards the lower
10 end of said expandable portion, and means for releasably
mounting the tubing on the mandrel, the tubing being
releasable from the mounting means by manipulation of the
mandrel following fixing of the tubing in the bore, and the
mounting means being re-engageable with the tubing by
15 further manipulation of the mandrel to permit manipulation
of the tubing to release the fixing means and permit
withdrawal of the assembly from the bore.

2. The assembly of claim 1, wherein means is also
provided for releasing the expanding means from the
20 mandrel.

3. An assembly for installing expandable tubing in a bore, the assembly comprising:

a length of tubing including an expandable portion and
means for releasably fixing the tubing in the bore;

a mandrel for connection to a running string and for carrying the tubing into the bore, the mandrel including means for expanding the expandable portion of tubing, said expanding means being initially located towards the lower end of said expandable portion; and

5 means for releasably mounting said expanding means on the mandrel, whereby the expanding means is releasable from the mandrel to permit withdrawal of the assembly from the tubing and the bore.

10 4. The assembly of claim 3, wherein the mandrel further includes means for expanding the expandable portion of tubing, said expanding means being initially located towards the lower end of said expandable portion, and means for releasably mounting the tubing on the mandrel, the

15 tubing being releasable from the mounting means by manipulation of the mandrel following fixing of the tubing in the bore, and the mounting means being re-engageable with the tubing by further manipulation of the mandrel to permit manipulation of the tubing to release the fixing

20 means and permit withdrawal of the assembly from the bore.

5. The assembly of claim 2 or 4, wherein the expanding means and the means for releasably mounting the tubing to the mandrel are linked and are releasable from the mandrel as one.

25 6. The assembly of claim 2, 3, 4 or 5, wherein the means

for releasing the expanding means from the mandrel is actuatable by fluid pressure.

5 7. The assembly of claim 6, wherein the means for releasing the expanding means from the mandrel is actuatable by means of fluid pumped from the surface through the running string and a fluid passage defined by the mandrel.

10 8. The assembly of claim 7, wherein a restriction is provided for location in the passage, to allow creation of a pressure drop and actuation of an axially movable piston to release keys locking the expanding means and the mandrel together.

15 9. The assembly of any of claims 1, 2 or 4 to 8, wherein the means for releasably mounting the tubing to the mandrel includes an open-ended J-slot arrangement, such that re-engagement of the tubing with the mounting means may be achieved merely by manipulation of the running string.

20 10. The assembly of any of claims 1, 2 or 4 to 9, wherein the means for releasably mounting the tubing on the mandrel includes a link for fixing the tubing on the mandrel while running in to the bore, to minimise the possibility of the tubing being inadvertently released from the mandrel by the shocks and bumps experienced during run in.

11. The assembly of claim 10, wherein the link is a shear link.
12. The assembly of any of the preceding claims, wherein the means for releasably fixing the tubing in the bore includes means for automatically latching the tube in the bore on downward axial movement of the tubing relative to the bore and means for releasing the tubing from the bore on one or both of subsequent axial movement of the tubing relative to the bore and rotational movement of the tubing relative to the bore.
13. The assembly of claim 12, wherein said automatic latching means and tubing releasing means are combined in a single fixing means.
14. The assembly of any of the preceding claims wherein the assembly includes a barrier to prevent debris falling into the upper end of the tubing, which debris might otherwise interfere with the movement of the expanding means through the tubing.
15. The assembly of claim 14, wherein the barrier is in the form of a junk catcher for mounting on the lower end of the string or the upper end of the mandrel.
16. The assembly of any of the preceding claims wherein a sand screen or the like is mounted on the tubing, to be

pushed into contact with the bore wall on expansion of the tubing.

17. An assembly for installing expandable tubing in a bore, the assembly comprising:

5 a length of expandable tubing including an anchor for releasably fixing the tubing in the bore; and

a mandrel for connection to a running string and for carrying the tubing into the bore, the mandrel including an expander cone initially located towards the lower end of the tubing, and a coupling for releasably mounting the tubing on the mandrel, the coupling releasing the tubing from the mandrel with manipulation of the mandrel following fixing of the tubing in the bore, and the coupling re-engaging the tubing with further manipulation of the mandrel, to permit manipulation of the tubing to release the anchor and permit withdrawal of the assembly from the bore.

18. An assembly for installing expandable tubing in a bore, the assembly comprising:

20 a length of expandable tubing including an anchor for releasably fixing the tubing in the bore;

a mandrel for connection to a running string and for carrying the tubing into the bore, the mandrel including an expander cone initially located towards the lower end of the tubing; and

25 a coupling for releasably mounting the cone on the

mandrel, whereby the cone is releasable from the mandrel to permit withdrawal of the assembly from the tubing and the bore.

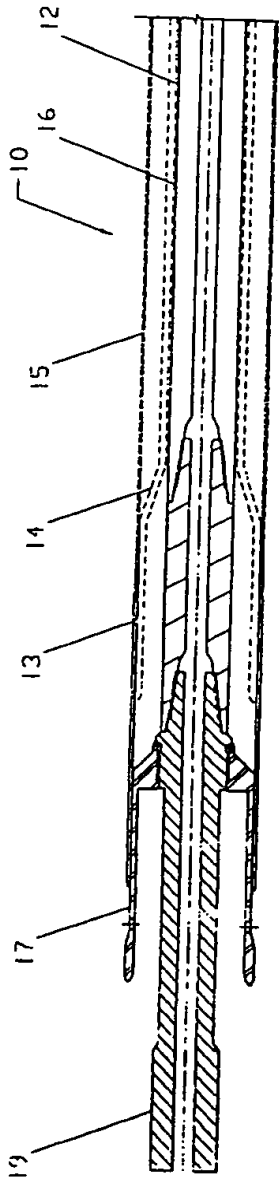

FIGURE 1a

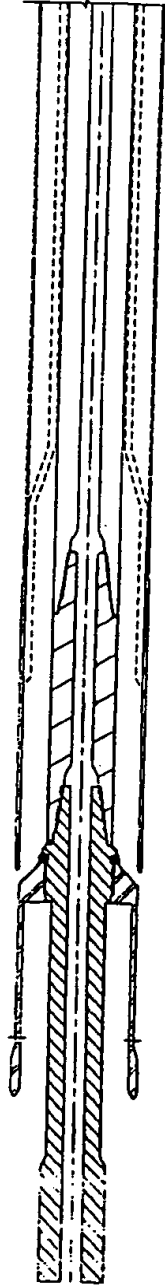

FIGURE 4a

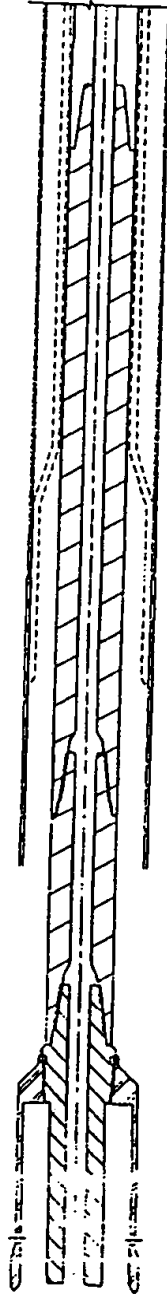

FIGURE 5a

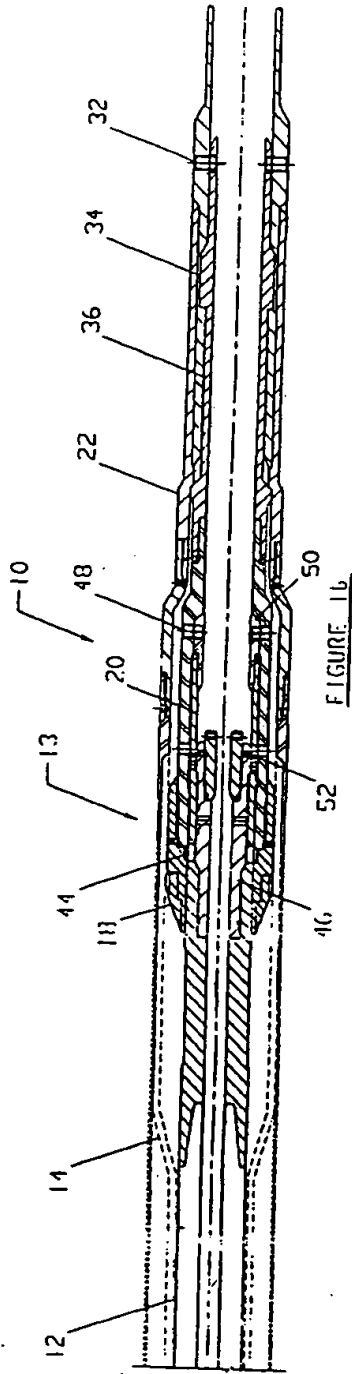

FIGURE 1a

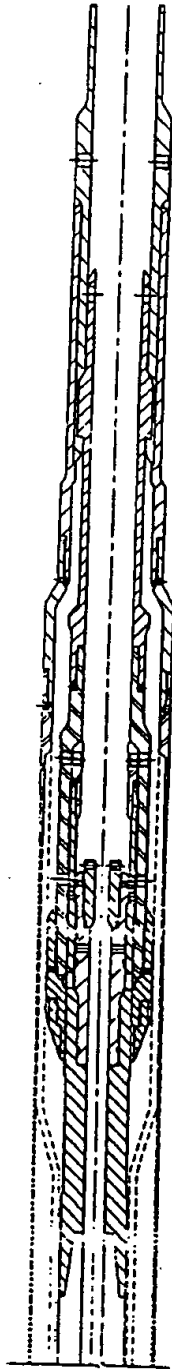

FIGURE 4b

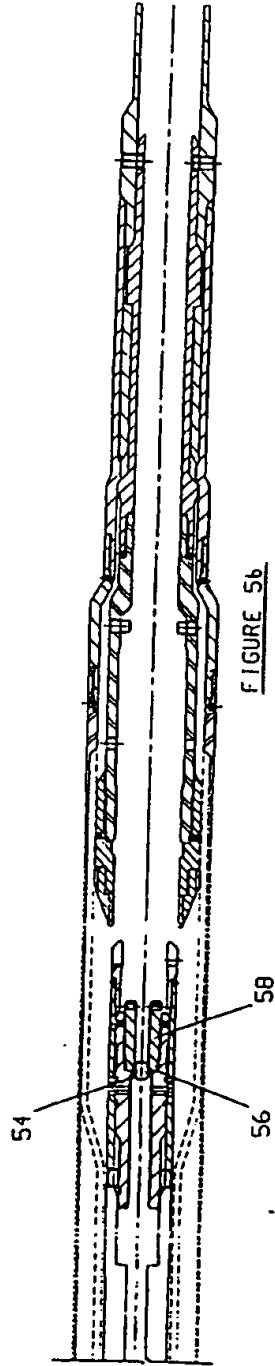

FIGURE 5b

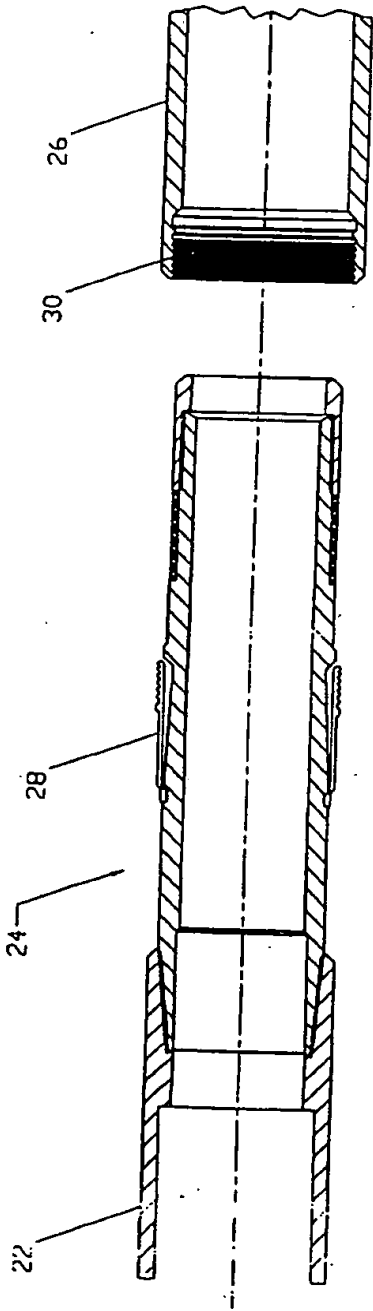

FIGURE 2

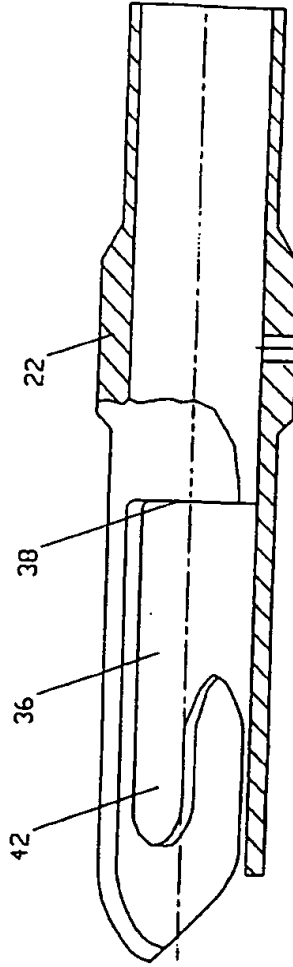

FIGURE 3